

Course/Topic: TV Engineering / **Monochrome TV Transmitter**

Course Outcome:

Activity Chosen: Animation video

Faculty: N.S.V .L Sowjanya

Animation video

Over the past few years, videos are being widely used in classrooms for supporting a teacher's curriculum and helping students learn the material faster than ever. Research shows that 94% of the teachers have effectively used animation videos during the academic year and they have found video learning quite effective, it is even better than teaching students through traditional text-books. Majority of part of the human brain is devoted towards processing the visual information. Brain responds to visuals fast, better than text or any other kind of learning material. Remembering stuff from the picture is retained in the mind for a longer time. Through videos, students get to process information fast.

Details of the Implementation:

- Animation provides opportunities for real communication between teachers and students in learning.
- Use of audio-visual aids help in maintaining discipline in the class since all the students' attention are focused in learning. This interactive session also develops critical thinking and reasoning that are important components of the teaching-learning process.
- Students learn when they are motivated and curious about something. Traditional verbal instructions can be boring and painful for students. However, use of audio-visual provides intrinsic motivation to students by peaking their curiosity and stimulating their interests in the subjects.



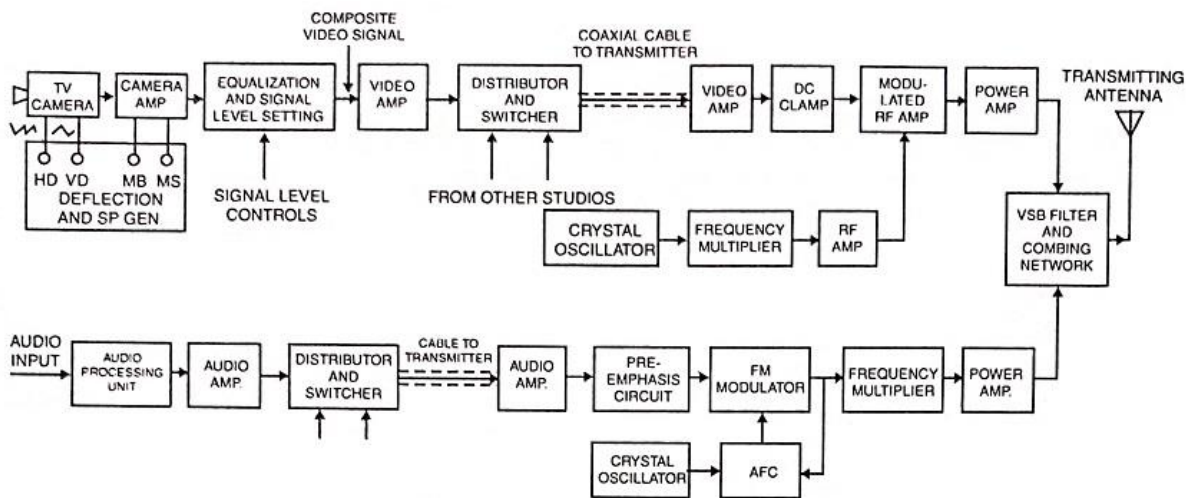

Fig. 23.34 Block Diagram of a Monochrome Transmitter

The term monochrome stands for black and white. Thus a monochrome TV system does not process variations of colour in a picture but processes only the intensity of brightness of each pixel for transmission in space. The picture is reproduced on the fluorescent screen of the monochrome picture tube in a receiver, in shades of white and black. At transmitter, picture carrier frequency assigned to the station is generated, amplified and later amplitude modulated with the incoming composite black and white signal. The sound output associated with the scene is simultaneously processed and frequency modulated with the channels and carrier frequency. The two outputs, one from the picture signal transmitter and the other from the sound signal transmitter are combined in a suitable network and then fed to a common antenna network for transmission

Deflection Circuit : The function of scanning is to convert the charge image into video signal, varying with time, to make it suitable for radio transmission. This is done by deflecting a well focused beam of electrons on the charge image horizontally and vertically. The deflection circuits are linear sawtooth signals. Scanning of one horizontal line takes $64 \mu\text{s}$. Vertical scanning is relative slow and is completed in two sequences, each sequence is completed in 20 ms.

Blanking and Synchronizing Pulses : In the scanning process the linear ramp of sawtooth signal provides sweep or trace and the falling edge, also called fly back provides retrace. The retrace will distort the video signal, thus these are blanked by cutting off the beam using appropriate blanking pulses.

Synchronization pulses trigger the sawtooth generators at the correct instant of time to start scanning. Triggering of horizontal sweep generator is done by the leading edge of the H-sync and that of vertical sweep is done by a specified voltage attained by the vertical sync. Video signal combined with sync pulse and blanking pulse is called composite video signal. The

purpose of transmitting the sync pulses along with the video signal is to use them to synchronize the sawtooth generator in the receiver with those in the Monochrome TV Transmitter.

Video Amplifier : It is a wideband amplifier and amplifies signals from a few Hz to 5.75 MHz. Composite video signal (CVS) is amplifier and gives sufficient power required for amplitude modulation. The video signal is made of negative polarity i.e. the white has low amplitude and the black, high amplitude.